

Operation and Installation Guide

1.0 Description

- The C900 is designed to link an alarm panel's digital dialer to a host computer by connecting one side to the Public Switched Telephone Network (PSTN) and the digital dialer's telco interface, and the other side to the host computer's RS-232 serial port.
- When the dialer has something to report, the C900 provides the signals and voltages necessary to simulate a connection to the central station through a PSTN. The C900 then decodes the transmitted digital dialer message and presents the decoded signals to the host computer. When the host computer acknowledges receipt of the message, the C900 transmits an appropriate acknowledge message to the dialer. True end-to-end security is maintained in this manner.
- The C900 has two RJ45 jacks. One is labeled "TELCO", and is intended for connection to an RJ31X jack. The other is labeled "PANEL", and it is intended for connection to a digital dialer via a telco cord. In "Intercept Mode," the C900 connects the house phone directly to the telephone company, and connects the digital dialer to its internal telco simulation electronics. In "Fallback Mode," the C900 connects the house phone to the dialer, and the dialer to the telephone company, shunting itself out of the phone circuit. Intercept Mode is maintained only if the C900 CPU is functioning (Output 1 held low). "Fallback Mode" is thus ensured in the event of a CPU lockup.

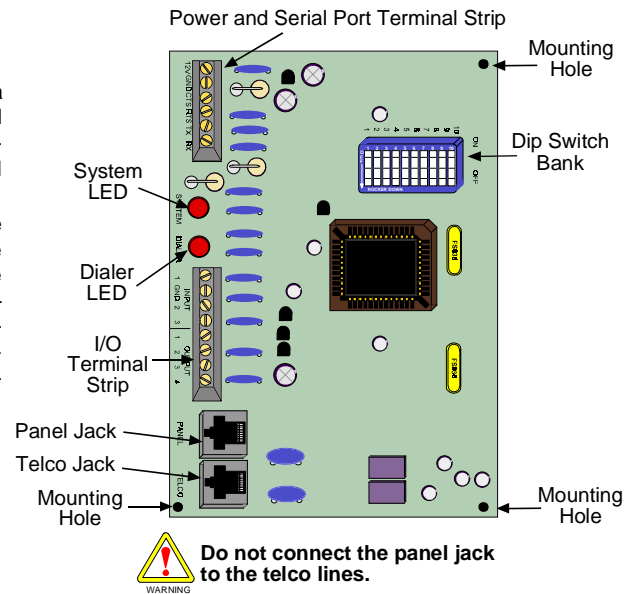

Figure 1: C900 Dialer Capture Module

2.0 Specifications

- **Voltage Range:** 9.6 - 15.0 VDC
- **Current:** 100 mA
- **Size:** 3.25 in. x 5.5 in. (8.3 cm x 14 cm)
- **Operating Temperature:** +32° to 120° F (0° to 49°C)
- **Ringer Equivalency Number (REN):** 3B*
- * The C900 itself does not have a REN, but the panel and the phone should add up to less than 3.

3.0 Wiring

- Connect the power and data wiring as shown below:

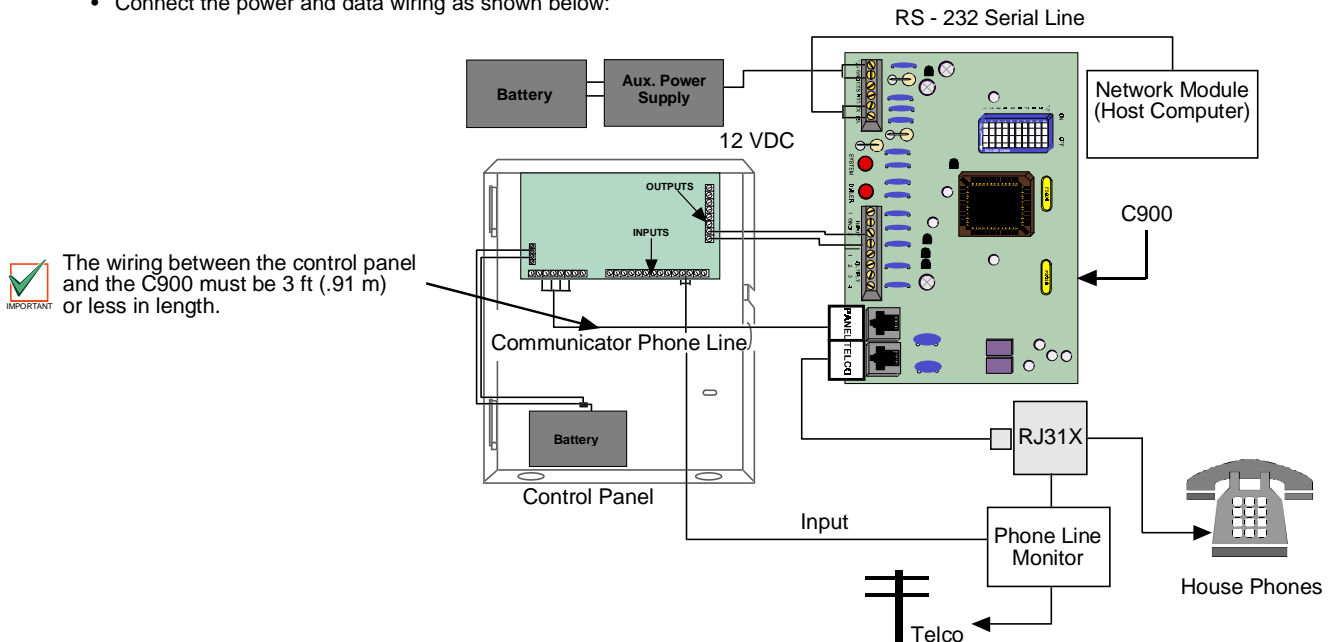

IMPORTANT The wiring between the control panel and the C900 must be 3 ft (.91 m) or less in length.

Figure 2: Wiring the C900

4.0 Mounting

- The C900 can be mounted to a Three-Hole Mounting Configuration. Use the existing holes in the enclosure, or drill three 3/16 in. holes at the dimensions shown in the accompanying diagram.
- A D137 Mounting Bracket can be purchased at Radionics by contacting the Radionics Customer Service Department.

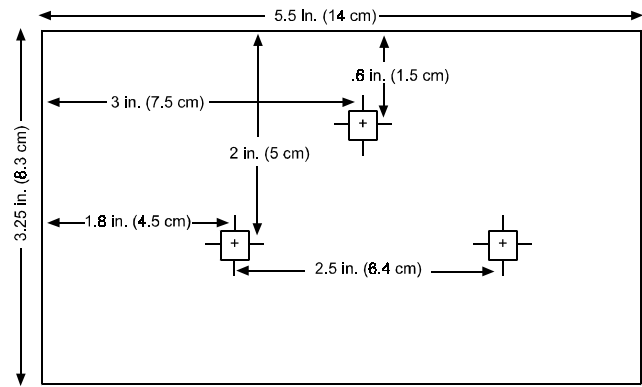

Figure 3: Three-Hole Mounting Configuration

5.0 Installation Notes

- The C900 intercepts the phone line between the service and the panel, thus rendering the panel's phone line monitor inactive. If phone line monitoring is required, an external phone line monitor, such as the Detection Systems Inc. DS7481, should be used.
- Panels with internal phone line monitors may generate an error when attached to the C900. Unless the internal phone line monitor can be disabled, do not use such a panel with the C900.

6.0 Dip Switch Settings

- The C900 is programmed by a 10 position dip switch:

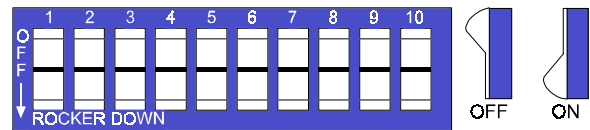

Figure 4: C900 Dipswitch Bank

- The following tables define dip switch settings and functions as well as the expected digital dialer format for Dialer Formats DF 1 through DF4.

Table 1: C900 Dip Switch Functions

Switch	OFF	ON
1	DF1	
2	DF2	
3	DF3	
4	DF4	
5	Disable auto fallback after intercept error ⁱ	Enable auto fallback after intercept error
6	No number of hang-ups will cause fallback.	Third hangup without host ACK causes error ⁱⁱ
7	30 second idle poll ⁱⁱⁱ	240 second idle poll
8	Handshake after 1 second break in dialing ^{iv}	Handshake after 6 second break in dialing
9	Unused	Unused
10	1200 baud RS-232 data rate	9600 baud RS-232 data rate

ⁱ Several errors can occur in the intercept process. Any error will force the C900 to switch the dialer to the fallback position for 2 minutes when it next seizes the line (if enabled, and if the seize occurs within 2 minutes). Intercept errors are always reported to the host computer.

ⁱⁱ If the host computer does not acknowledge a report that was intercepted by the C900 in the proper amount of time, the digital dialer will hang up and retry the message transmission. The proper amount of time is measured in terms of a failed message transmission at the digital dialer. Based on the number of hang-ups the C900 will switch to Fallback Mode.

ⁱⁱⁱ The time in seconds that will elapse between polls when the C900 is idle (for example, not expecting a dialer acknowledge). Default is 30 seconds.

^{iv} Depending on programming, the C900 will generate the appropriate handshake either 1 second or 6 seconds after the digital dialer has finished dialing.

7.0 Input/ Output Functions

7.1 Inputs

- The C900 has 3 inputs monitored by A/D converters. They serve the following functions:
- Input 1:** Used as an EOL supervised loop. If status reports are enabled, then any voltage **above** 3.33 VDC is reported as an open condition to the host. Any voltage **below** 1.66 volts is reported as a short. Input 1 must be EOL terminated with a 10 K resistor.
- Input 2:** Used for Intercept Inhibit. If input 2 goes **above** 1.66 volts, then the C900 is immediately forced into Fallback Mode for a minimum of 2 minutes. Input 2 must go low for **at least** 5 seconds to be considered low. Input 2 is intended for connection to a fire bell to force fire reports to be sent digitally. If input 2 is unused, it may be left disconnected.
- Input 3:** Used for Intercept Override. If input 3 goes **above** 1.66 volts for 5 seconds, then the C900 enters into Fallback Mode. If input 3 goes low, then the C900 will return to Intercept Mode. If this input is driven by a ground start relay output, the C900 will stay in Fallback Mode except when the dialer wishes to dial. Input 3 cannot force an intercept if the C900 is in Fallback Mode due to an error, a command or an Input 2 high condition. If input 3 is unused, it may be left disconnected.

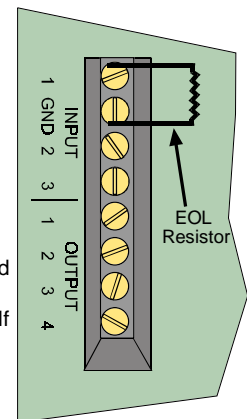

Figure 5: I/O Terminal Strip

7.2 Outputs

- The C900 has 4 open-collector outputs:
- **Output 1:** Active (shorted to ground) as long as the CPU is functioning normally. If the CPU fails to operate or the CPU loses power, output 1 will be open.
- **Output 2:** Active as long as the host computer is working properly, and open when the host computer has failed.
- **Output 3:** Active whenever the C900 is in Intercept Mode.
- **Output 4:** Controlled by command from the host computer (default is open).

8.0 Power and Serial Port Terminal Strip Description

- The following list describes the functions of the Power and Serial Port Terminal Strip:
- **+12 V:** Connect regulated/ or unregulated 12 volt DC power to this terminal and the GND terminal. This power may be supplied by a separate power supply, battery, or Auxiliary power from the Control/ Communicator.
- **GND:** Return terminal for the 12 VDC power supply. This is also the ground reference for the Serial port.
- **CTS:** Clear to Send; used for hardware handshake (not currently implemented).
- **RTS:** Request to Send; used for hardware handshake (not currently implemented).
- **TX:** Transmit data line, RS-232 voltage levels.
- **RX:** Receive data line, RS-232 voltage levels.

9.0 RS - 232 Serial Line Configuration

- Table 3 shows the pin connections between the C900 and a DB9 or DB25 serial port connector:

Table 3: Serial Port Connections

C900DC Terminal	DB9 Connector Pin	DB25 Connector Pin
GND (ground)	5 (GND)	7 (GND)
TX	3 (T x D)	3 (T x D)
RX	2 (R x D)	2 (R x D)

Table 2: Digital Dialer Protocol for Switches DF1-DF4

DF1	DF2	DF3	DF4	Format
OFF	OFF	OFF	OFF	Radionics Modem IIe and Modem IIIa ²
OFF	OFF	OFF	ON	Radionics Modem II
OFF	OFF	ON	OFF	Any Ademco DTMF
OFF	OFF	ON	ON	Any Ademco DTMF; dialer retransmits quickly
OFF	ON	OFF	OFF	Radionics BFSK, 2300 Hz ACK
OFF	ON	OFF	ON	Radionics BFSK, 1400 Hz ACK
OFF	ON	ON	OFF	Reserved
OFF	ON	ON	ON	Reserved
ON	OFF	OFF	OFF	Any pulse, 2300 Hz ACK
ON	OFF	OFF	ON	Any pulse, 1400 Hz ACK
ON	OFF	ON	OFF	Any pulse, long 2300 Hz ACK
ON	OFF	ON	ON	Any pulse, long 1400 Hz ACK
ON	ON	OFF	OFF	Unused
ON	ON	OFF	ON	Unused
ON	ON	ON	OFF	Unused
ON	ON	ON	ON	Unused

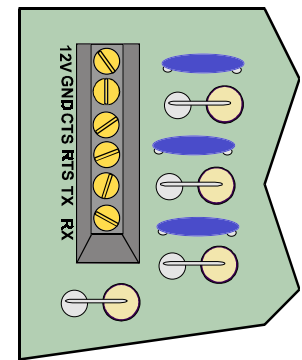

Figure 6: Power and Serial Port Terminal Strip

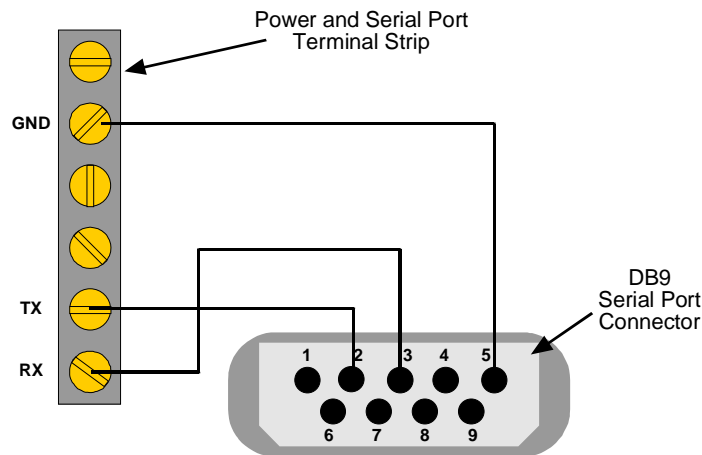

Figure 7: Power and Serial Port Terminal Strip Connections

10.0 C900 Troubleshooting

10.1 LED Description

- The C900 has two LEDs that indicate its status: the DIALER LED and the SYSTEM LED.

DIALER LED

- The DIALER LED indicates the status of the digital dialer interface (Hertz = cycles/flashes per second).**
 - The Dialer LED functions as follows:
 - Off:** The C900 is in permanent Fallback Mode due to command or no power.
 - Green:** The C900 is in Intercept Mode and the dialer is on-hook.
 - Blinking green (5 Hertz):** The C900 is in Intercept Mode and the dialer is off-hook.
 - Red:** The C900 is in Fallback Mode due to error, the Intercept Inhibit or Override inputs, or command.
 - Blinking red (5 Hertz):** The previous (or current) off-hook caused an intercept error. ⁱ
 - Alternating red/ green (5 Hertz):** The dialer is off-hook, but the last message was rejected due to a bad checksum or other logical error. ⁱⁱ
- ⁱ If Auto Fallback After Error is enabled (Switch 5 = ON), the C900 will connect the dialer to the phone line on the next line seizure. If the dialer does not seize the line, this condition terminates after 2 minutes.
- ⁱⁱ If the dialer subsequently sends a valid message, the LED will return to a blinking green status. If the dialer hangs up, an intercept error will be generated. The alternating LED also occurs when the line is currently seized, but no transaction is taking place (for example, the C900 is waiting for the dialer to return on-hook). This happens when the C900 returns to Intercept Mode, or while the dialer has seized the line.

SYSTEM LED

- The SYSTEM LED indicates the status of the host computer and the C900 itself.**
- The System LED functions as follows:
 - Blinking green (5 Hertz):** The host computer is responding normally.
 - Blinking red (5 Hertz):** The host computer is not responding.
 - Blinking red (repeating code):** A self-test has occurred. The code is a series of rapid blinks that repeat every second:
 - 1 blink:** ROM checksum error.
 - 2 blinks:** RAM test error.
 - Steady green, red or off:** The C900 has failed or has no power.



The DIALER LED is invalid, and the C900 will be in Fallback Mode and will not poll the host in the latter two cases (**Blinking red (repeating code)** or **Steady green, red or off**).

10.2 Fallback Mode

- In fallback operation, the C900 connects the house phone to the dialer and the dialer to the telco, shunting itself out of the phone circuit. Intercept mode is maintained only if the C900 processor is running, and there are no errors. Thus, "Fallback Mode" is ensured in the event of a CPU lockup.

10.3 Dialer Interaction

- The following table shows the conditions under which the C900 will go into "Fallback Mode." The C900 will return to intercept only when all "Until" conditions are met.

Table 4: Fallback Mode Conditions

What	When	Until
CPU fail	Immediately	C900 restart
Host link fail	Immediately	Link is restored
Host link failing (no response to last message)	Dialer goes off-hook	Link is restored
Intercept Disable command	Immediately	Intercept Enable command
Intercept error	The fallback after intercept error is enabled, and the dialer goes off-hook within two minutes of the error occurrence.	Two minutes
Switch to Fallback command	Upon receipt. Will not actually fallback until the dialer is on-hook.	One hour or Intercept Enable command
Input 2 (intercept inhibit)	High for 200 mS	Low for 5 seconds, after minimum fallback of two minutes.
Input 3 (intercept override)	High for 5 seconds. Will not actually fallback until the dialer is on-hook.	Low for 200 mS.